



125 years of innovation

Instrument Calibration Methods

AMETEK
ULTRA PRECISION TECHNOLOGIES

Contents

- Gauge Gain Calibration
 - Slip Blocks
 - Flick (Magnification) Standard
- Crutch Angle Effects
- Radial Accuracy of the Spindle
 - Hemisphere

Gauge Gain Correction – Slip Blocks



Global Excellence in Metrology

 TAYLOR HOBSON®

 **AMETEK**
ULTRA PRECISION TECHNOLOGIES

The above slide shows the Slip Block set used for the gain calibration of the stylus and gauge of a Talyrond instrument.

The set comprises of a circular glass flat and three slip gauges to allow calibration of the two gauge ranges.

Gauge Gain Correction – Slip Blocks

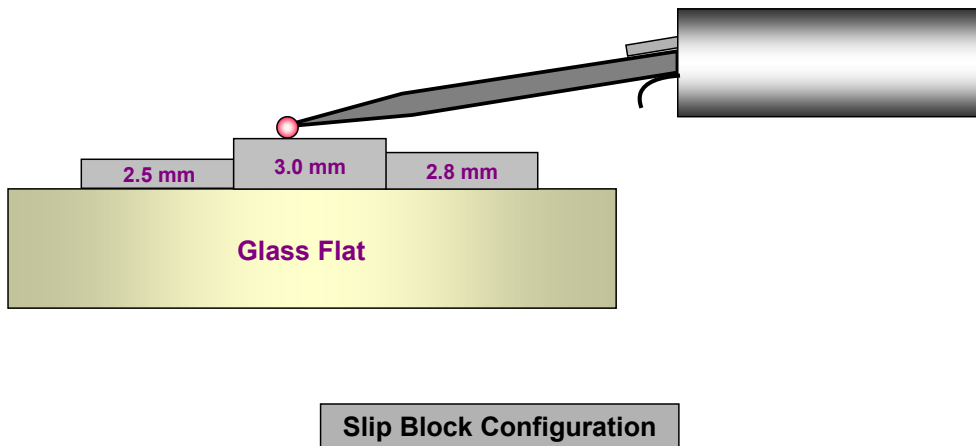

Global Excellence in Metrology

 TAYLOR HOBSON®

 **AMETEK**
ULTRA PRECISION TECHNOLOGIES

The gain correction of the gauge and stylus combination plays an essential part in eliminating inaccuracies in the measurement loop.

One high accuracy method of correcting the gain is by traversing the instrument stylus over a known step height and comparing the measured value against the step value to determine the correction factor, which can then be applied to all subsequent measurements.

The above set up comprises of a glass flat and three slip blocks which are wrung on to the surface of the glass flat. These are arranged such that they form two separate step heights, one height for each gauge range.

Gauge Gain Correction – Slip Blocks

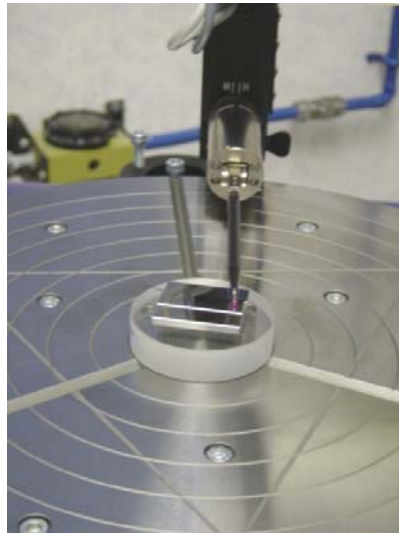

Global Excellence in Metrology

 TAYLOR HOBSON®

 **AMETEK**
ULTRA PRECISION TECHNOLOGIES

Prior to calibration it is important that the surface of the glass flat is leveled and is square to the spindle axis.

It is also important that the step height is measured equally about the centre of the instrument gauge range.

Gauge Gain Correction – Flick (Magnification) Standard

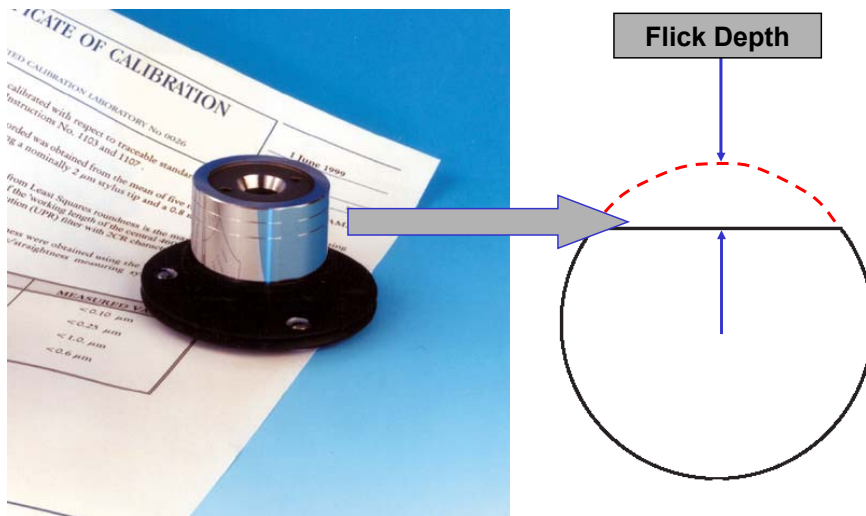

Global Excellence in Metrology

 TAYLOR HOBSON®

 **AMETEK**
ULTRA PRECISION TECHNOLOGIES

The magnification (Flick) standard is simply a precision ground cylinder with a flat ground to a nominal depth from the major diameter.

When a roundness measurement is performed the flat generates a deflection as the stylus traverses the component. The measured deflection is then compared against the calibrated value of the flick standard and a gain correction factor is calculated. Subsequent measurements can then be made with the gain correction factor applied.

Gauge Gain Correction – Flick (Magnification) Standard

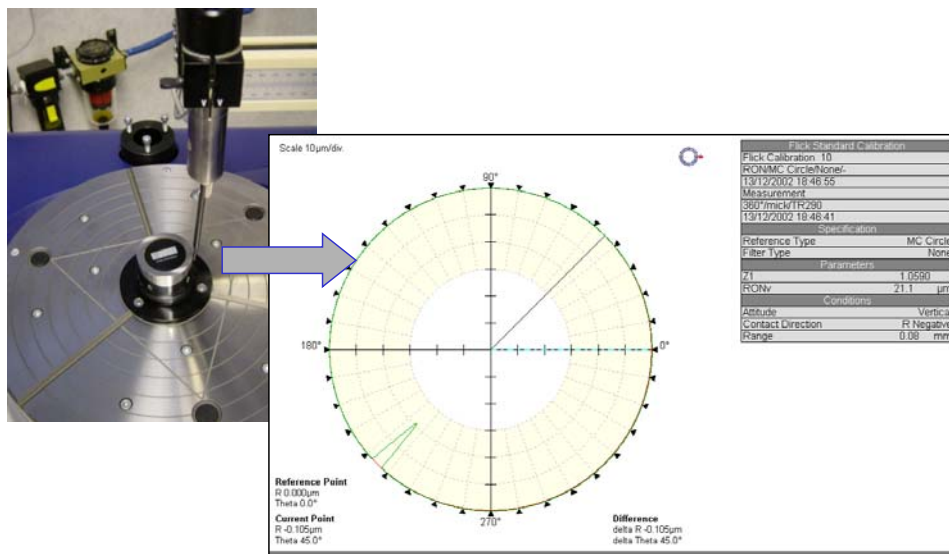

Global Excellence in Metrology



AMETEK
ULTRA PRECISION TECHNOLOGIES

This method of calibration is generally used for calibrating longer length styli, in other words styli that cannot be calibrated with the gauge in the horizontal attitude.

For this method of calibration the stylus is normally positioned in the vertical attitude, due to the fact that if positioned horizontally the stylus would move off the crest of the component as it traversed over the flick portion of the standard, so introducing cresting errors.

Prior to calibration the standard should be accurately centred and levelled to remove any inaccuracies that could be introduced by tilt and eccentricity.

When the stylus is in contact with the standard, it should be set up so as to ensure that the flick is measured equally about the middle of the instrument gauge range.

The above slide shows the calibration set up and result which is analysed using a minimum circumscribed reference circle.

Note that the flick deviation appears as a concave shape on the result. This is again due magnification effects.

Gauge Gain Correction – Crutch Angle Effects

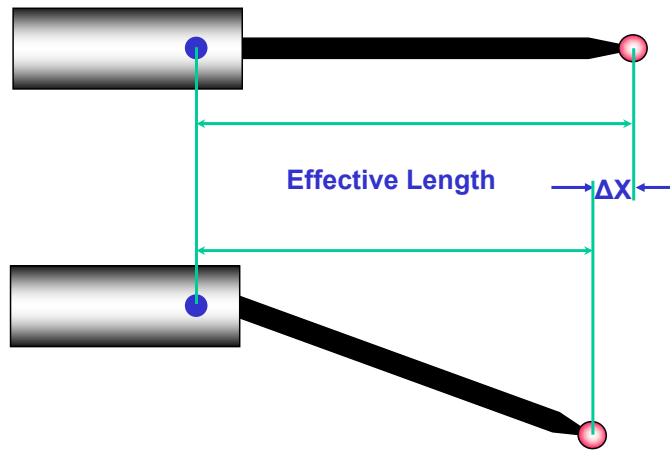

Global Excellence in Metrology

 TAYLOR HOBSON®

 **AMETEK**
ULTRA PRECISION TECHNOLOGIES

If the stylus is positioned in the gauge at a different crutch angle to the angle used during the slip block calibration the change in effective length (ΔX) will result in an error in the measurement. This may not be that significant on the majority of roundness measurements, however for certain high accuracy measurements this error may be of importance.

Therefore, for optimum accuracy the stylus should be used at the same crutch angle as was used for the slip block calibration.

Radial Accuracy of Spindle



Glass Hemisphere

Global Excellence in Metrology

 TAYLOR HOBSON®

 **AMETEK**
ULTRA PRECISION TECHNOLOGIES

A precision glass hemisphere of known calibrated roundness is used to check the radial accuracy of the instrument spindle.

Radial Accuracy of Spindle

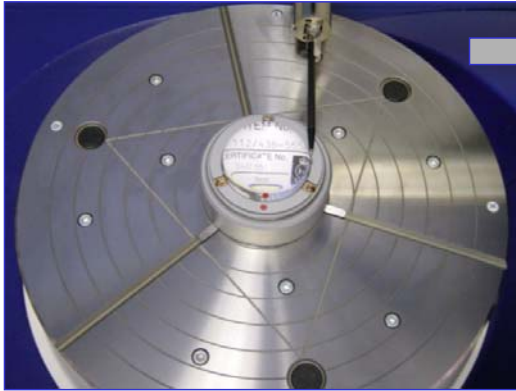

Red Dot at 270 Degree Position

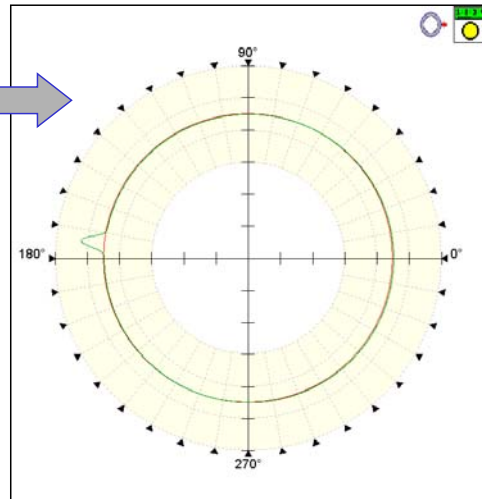

Global Excellence in Metrology

 TAYLOR HOBSON®

 **AMETEK**
ULTRA PRECISION TECHNOLOGIES

A precision glass hemisphere of known calibrated roundness is used to check the radial accuracy of the instrument spindle.

The hemisphere is accurately centred to the spindle axis and a measurement is taken.

The instrument spindle is then stopped and the hemisphere is taken off the instrument table and rotated by a nominal angle.

The hemisphere is again accurately centred to the spindle axis and a second measurement is taken at the new angular orientation.

Radial Accuracy of Spindle

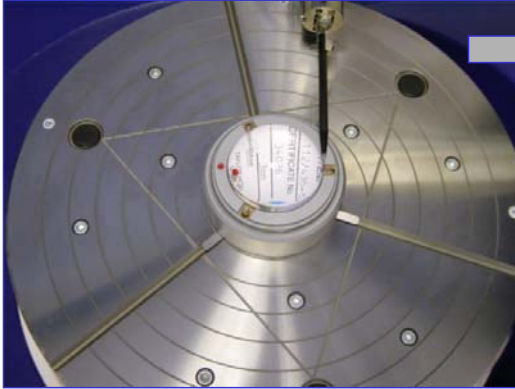

Red Dot at 180 Degree Position

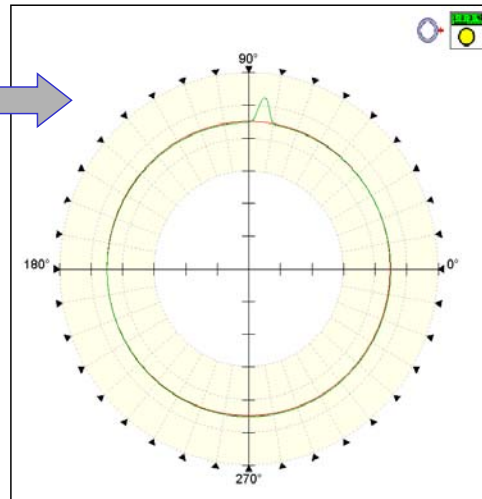

Global Excellence in Metrology

 TAYLOR HOBSON®

 **AMETEK**
ULTRA PRECISION TECHNOLOGIES

Any error in the result that has rotated by the same angle as the rotation of the hemisphere is not an error in the spindle. Errors that remain in the same angular position between measurements are errors in the spindle.

It is important to understand that this procedure is used only for checking to see that the instrument spindle radial errors are within the instrument's specification. It is not used for calibrating the gain of the gauge / stylus combination.

Summary

- Two methods of traceable Gauge Gain Calibration
 - Slip Blocks
 - Flick (Magnification) Standard
- Crutch Angle Effects
 - For optimum accuracy the stylus should be used at the same crutch angle as was used for the calibration.
- Radial Accuracy of the Spindle
 - Any errors that rotate in a result when the part has been rotated is part error. Errors that remain in the same angular position between measurements are errors in the spindle.



125 years of innovation

Roundness Component Setup

AMETEK
ULTRA PRECISION TECHNOLOGIES

Contents

- Kinematic Mounting
 - 3 Point Location
- Centring and Levelling
- Errors Due to Component Setup

Global Excellence in Metrology



AMETEK
ULTRA PRECISION TECHNOLOGIES

One of the most crucial factors when making any sort of measurement is the stability of component during measurement.

On roundness systems there are many ways to clamp the component whether it be some form of chuck or vice. However all of these clamping methods require stability on their mounting face.

For example if a person was to sit on a stool with four legs there is a strong chance that the stool will rock, a stool with three points will not rock.

Therefore where possible parts for measurement should be held on three point location.

Kinematic Mounting

4 Point Location - Tendency to Rock

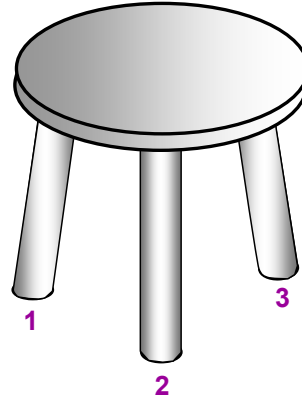
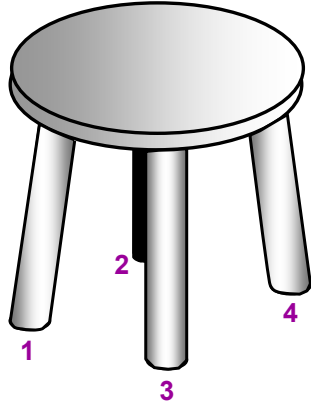

3 Point Location - Will Not Rock

Global Excellence in Metrology

 TAYLOR HOBSON®

 AMETEK®
ULTRA PRECISION TECHNOLOGIES

One of the most crucial factors when making any sort of measurement is the stability of component during measurement.

On roundness systems there are many ways to clamp the component whether it be some form of chuck or vice. However all of these clamping methods require stability on their mounting face.

For example if a person was to sit on a stool with four legs there is a strong chance that the stool will rock, a stool with three points will not rock.

Therefore where possible parts for measurement should be held on three point location.

Kinematic Mounting

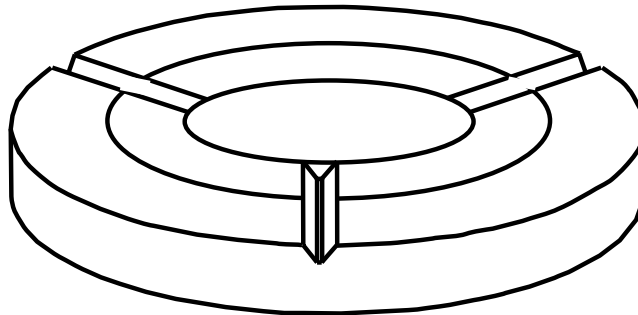

3 Point Location - On Instrument Table

Global Excellence in Metrology

 TAYLOR HOBSON®

 **AMETEK**
ULTRA PRECISION TECHNOLOGIES

As well as three point location we need lateral stability, especially where the component is quite light.

In the drawing above we can see a table with three grooves machined into its surface, these grooves serve three purposes.

Kinematic Mounting

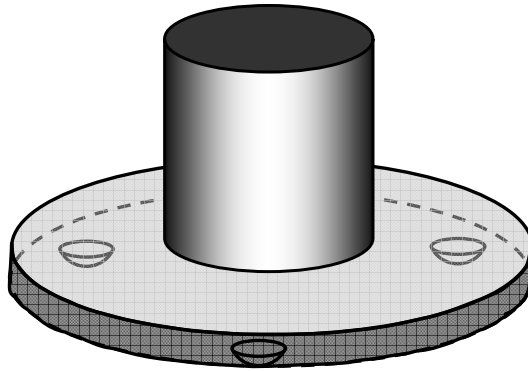

Component Fixture with 3 Mounting Feet

Global Excellence in Metrology

 TAYLOR HOBSON®

AMETEK
ULTRA PRECISION TECHNOLOGIES

If our component has a special mounting fixture, with three feet as in the case above.

Kinematic Mounting

- No Lateral Movement
- No Rocking
- Component Axis Centred

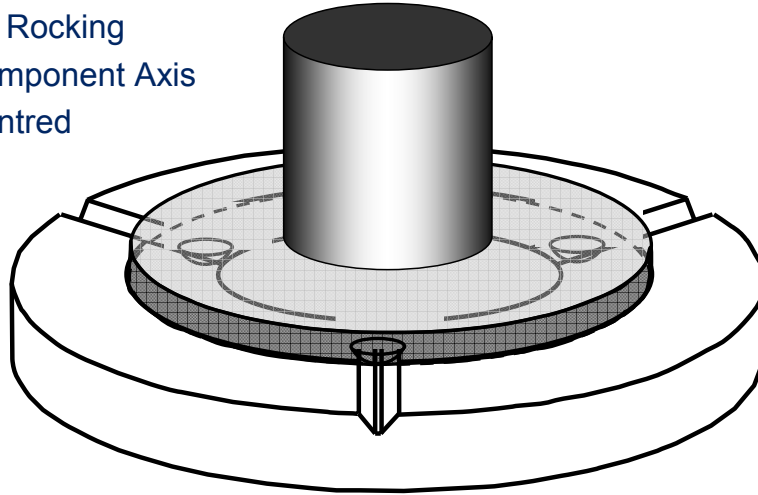

Global Excellence in Metrology

 TAYLOR HOBSON®

 **AMETEK**
ULTRA PRECISION TECHNOLOGIES

When placed on the table the three feet or in this case spherical balls will give three point location to prevent rocking.

They will locate in the grooves to prevent lateral movement and if the balls are set correctly to the grooves they will align the component centre to table centre reducing set up time.

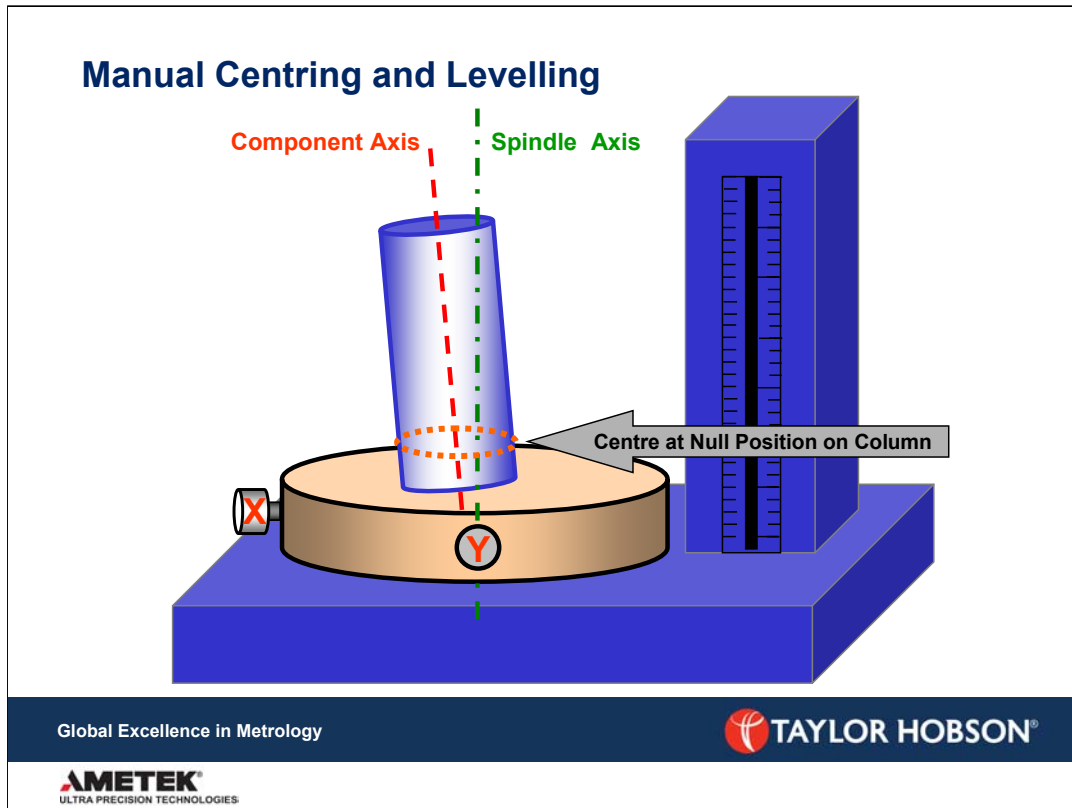

The above diagram shows the method for centring a component using a manual centring and levelling table.

The component should be kinematically mounted and located in the grooves of the instrument table.

The stylus should be contacted on to the component at the null position indicated on the column. This position identifies the pivot point of the levelling adjusters. This point is where the levelling of the component will have minimal effect on the component centring.

Centring adjustments are made using the X and Y centring adjusters to bring the component axis concentric with the spindle axis.

It is worth noting that with a cylindrical component, the measured plane may not be perpendicular to the cylinder axis at this point due to any tilting of the cylinder axis.

Manual Centring and Levelling Null Position

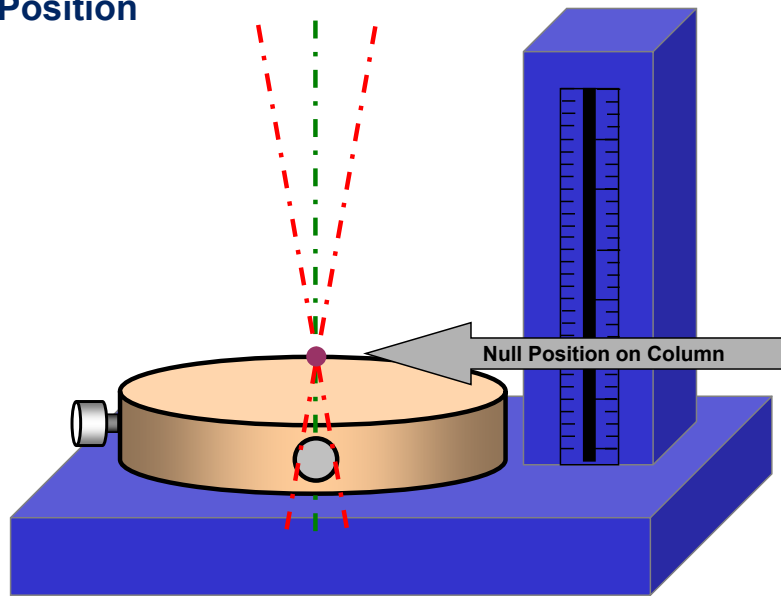

Global Excellence in Metrology

 TAYLOR HOBSON®

 **AMETEK**
ULTRA PRECISION TECHNOLOGIES

The null position (neutral plane) is the position about which the table tilt action is pivoted and provides a neutral plane. Centring carried out at this height will only require minimal re-centring after a levelling operation has been performed.

Manual Centring and Levelling

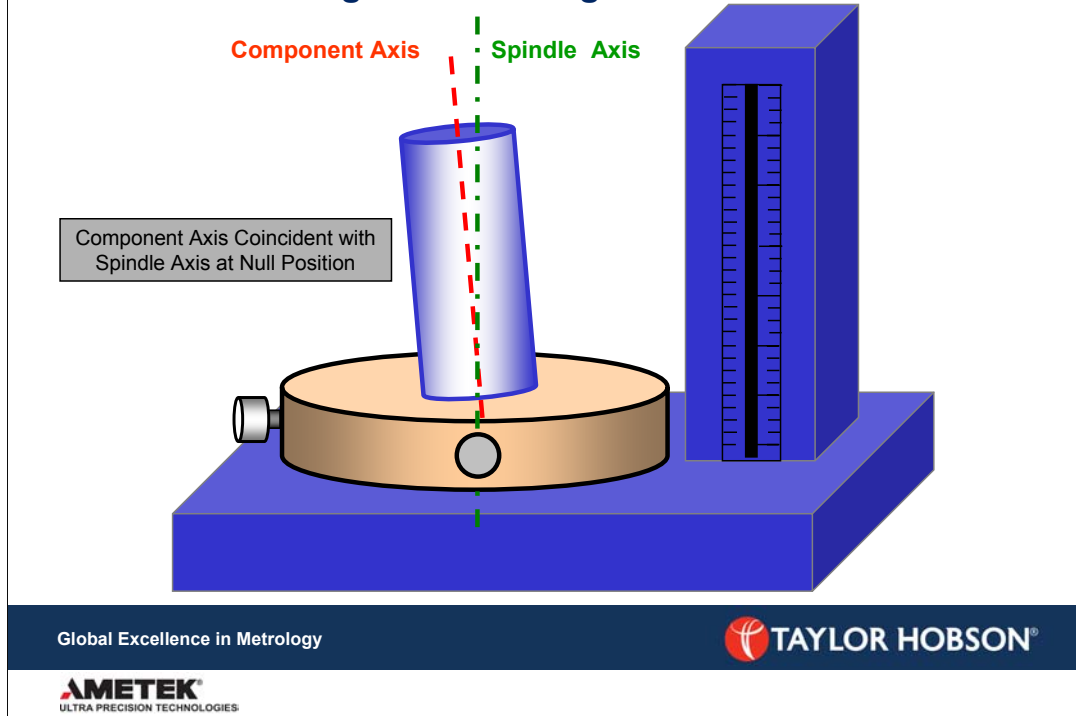

After adjustment the component axis (at the null position height) is now coincident with the spindle axis.

Manual Centring and Levelling

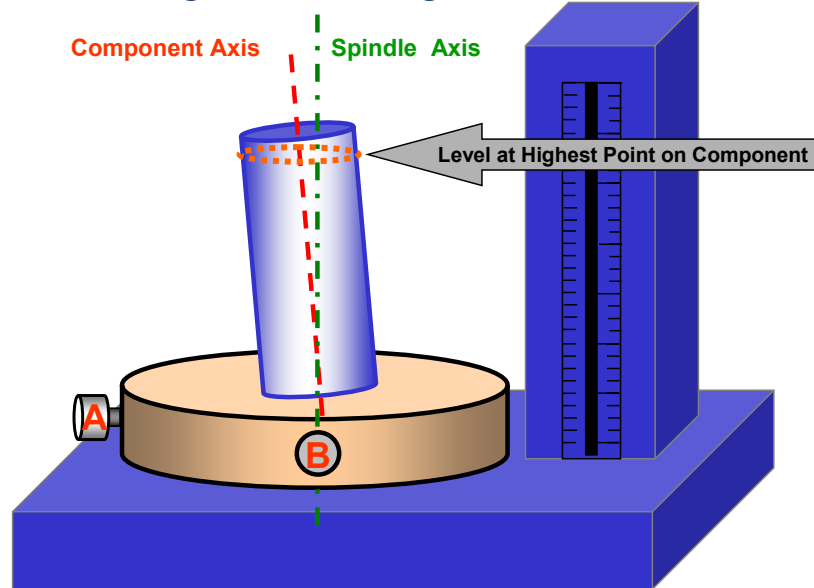

Global Excellence in Metrology

 TAYLOR HOBSON®

 **AMETEK**
ULTRA PRECISION TECHNOLOGIES

The next stage of the centring and levelling procedure is to position the stylus at the highest point possible on the component.

It is important that the centring plane and the levelling plane are as far apart as possible to obtain the optimum set up of the component.

Levelling adjustments are made using the A and B levelling adjusters to bring the component axis parallel with the spindle axis.

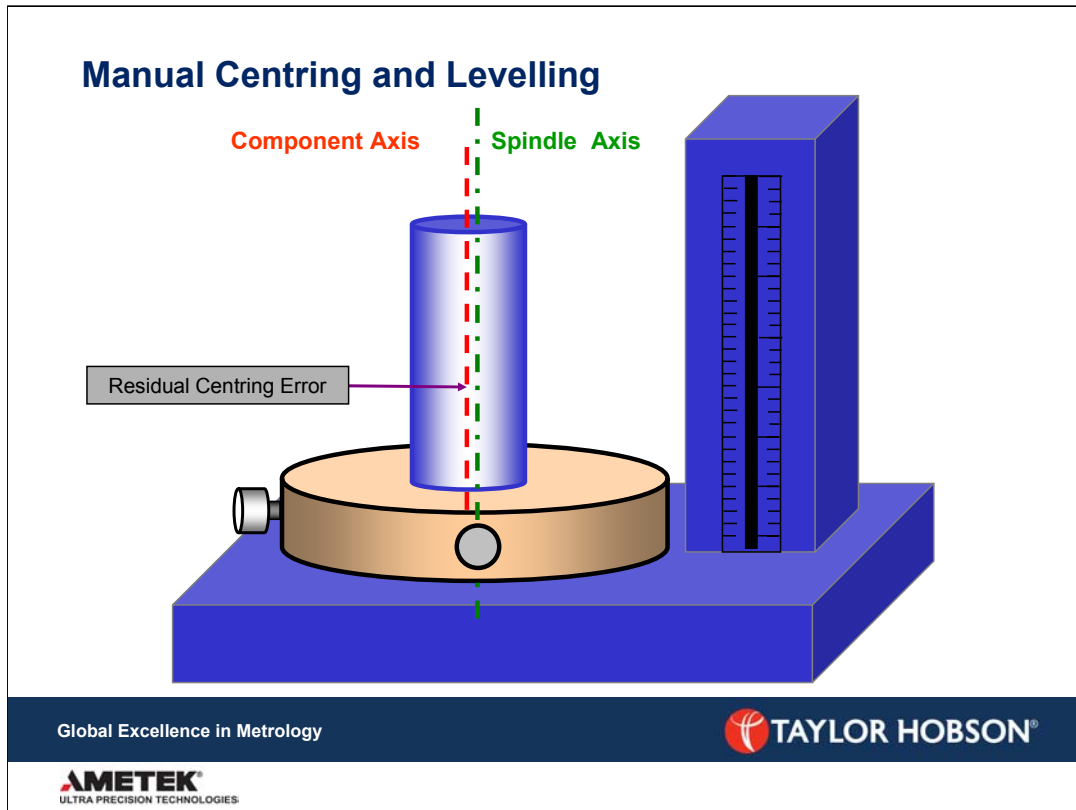

After adjusting the levelling, even though the two axes are parallel, it can be seen that there is a small residual centring error.

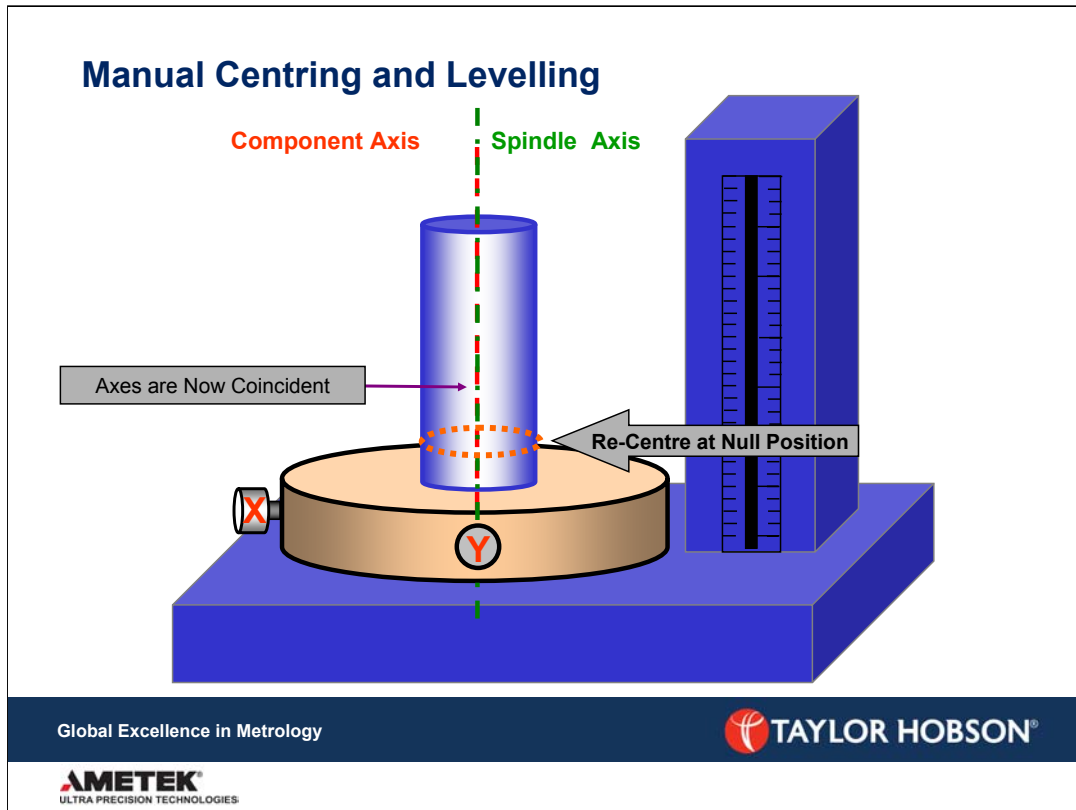

The residual centring error can now be corrected by re-centring at the null position, bringing the component axis coincident with the spindle axis.

Errors Due to Component Eccentricity

- The Degree to which a part needs to be centred mainly depends upon:
 - Expected (P-V) Roundness (Ront) in mm
 - Part Diameter (\emptyset) in mm
- Using the Formula

$$(RONT) \times (\emptyset)$$

... and the following graph

Global Excellence in Metrology



AMETEK
ULTRA PRECISION TECHNOLOGIES

The degree to which a part needs to be centred mainly depends upon:
The Expected (P-V) Roundness of the part (**RONT**) and the Diameter of the part. (\emptyset)

Using the graph shown on the following slide it is possible to calculate the possible effect on the roundness result due to component eccentricity as follows...

Errors Due to Component Eccentricity

- Example
 - To achieve <1% error
 - Part Diameter = 50mm
 - Expected RONT = 0.0001mm
 - $RONT \times \varnothing = 5 \times 10^{-3} \text{ (mm}^2\text{)}$

Ecc to be <0.7 μm

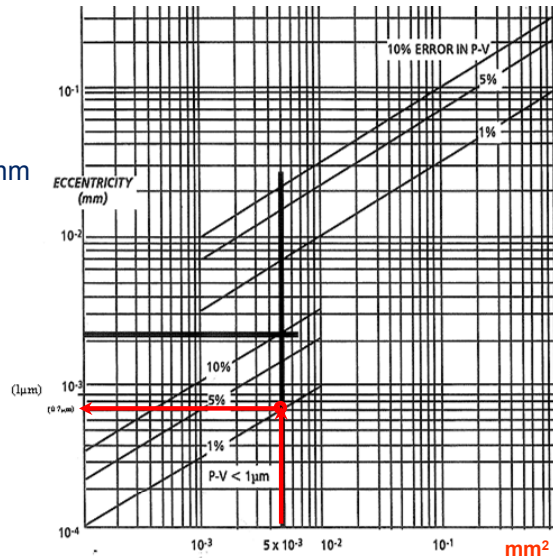

Global Excellence in Metrology

TAYLOR HOBSON®

AMETEK®
ULTRA PRECISION TECHNOLOGIES

Use the graph as follows:

1. Multiply the Expected Roundness (in mm) by the Part Diameter (in mm): $RONT \times \varnothing$ (mm²).
2. Find this position on the bottom axis of the graph.
3. Project a vertical line from this position.
4. For Expected Roundness < 1 μm use the lower set of lines on the graph.
5. For Expected Roundness > 1 μm use the upper set of lines on the graph.

Example

How well should the following component be centred to achieve less than 1% error (due to eccentricity) in the Roundness Result?

Part Diameter= 50mm, Expected Roundness= 0.0001mm (0.1 μm)

1. $RONT \times \varnothing = 5 \times 10^{-3} \text{ (mm}^2\text{)}$
2. Find this position on the bottom axis of the graph.
3. Project a vertical line from this position.
4. Note where this crosses the 1% line on the graph (Using the lower set of lines)
5. On the Vertical axis of the graph, note the corresponding Eccentricity value (E = 0.7 μm).

So, this part should be centred to no greater than 0.7 μm (Eccentricity) with respect to the Spindle Axis.

Summary

- Kinematic Mounting
 - A well designed kinematic mount gives no lateral movement, no rocking and a centred component axis ,reducing set up time.
- Centring and Levelling
 - Process to align component to spindle axis.
- Errors Due to Component Setup
 - The degree to which a part needs to be centred mainly depends upon: The Expected (P-V) Roundness of the part (**RONt**) and the Diameter of the part.

Global Excellence in Metrology



AMETEK
ULTRA PRECISION TECHNOLOGIES

One of the most crucial factors when making any sort of measurement is the stability of component during measurement.

On roundness systems there are many ways to clamp the component whether it be some form of chuck or vice. However all of these clamping methods require stability on their mounting face.

For example if a person was to sit on a stool with four legs there is a strong chance that the stool will rock, a stool with three points will not rock.

Therefore where possible parts for measurement should be held on three point location.

Contact us

- **Material produced by Taylor Hobson Centre of Excellence**
- **For more information contact:**
- email: taylor-hobson.cofe@ametek.com
- or call: +44 116 276 3779

- **Centre of Excellence Services**
- For calibration, training and precision metrology beyond the scope of your business expertise, the Taylor Hobson
- Centre of Excellence has experienced professional metrologists along with state of the art measuring instruments.

- **Metrology Training Courses**
- We offer standard and bespoke Training Courses in Surface Finish and Roundness, coupled with contact and non-
- contact Instrument Operator Training. To improve the understanding and application of Roundness and Surface Finish principles by your operators, inspectors and engineers.

- **Instrument Training**
- Without question, the benefits of training are exponentially greater than the cost. When your operators, inspectors
- and engineers are well versed in the theory and application of metrology they are more confident, more efficient, better informed and more likely to avoid mistakes or misrepresentation of results.

- **Technical Support**
- Manned by a team of Experienced Metrologist's, we provide a Case Study or Measurement Report Service alongside
- a Contract Measurement Service, to help in the correct selection of our metrology systems.

Global Excellence in Metrology



AMETEK
ULTRA PRECISION TECHNOLOGIES